



**Global Environmental Products Inc.** offers equipment with uncompromising performance, consistent quality, durability and reliability. Our comprehensive range of machines provide the right cleaning equipment for your application. Please contact us for a demonstration at (909) 713-1600.

- ▶ Reliable / Durable Equipment
- ▶ Innovative Engineering / Design
- ▶ Industry Leading Reputation
- ▶ Dedicated Customer Service
- ▶ Outstanding Sales Professionals
- ▶ Fast Parts and Service
- ▶ National Dealer Network

[www.GlobalSweeper.com](http://www.GlobalSweeper.com)

Sold and Serviced by:



**Global Environmental Products**  
 5405 Industrial Parkway  
 San Bernardino, CA 92407 USA  
 909-713-1600  
[info@globalsweeper.com](mailto:info@globalsweeper.com)



# CITYJET

## PERFECT SOLUTION FOR MUNICIPALITIES THAT WANT IT ALL

- ▶ With a 100% Stainless Steel Hopper designed to last.
- ▶ With powerful suction power the GLOBAL CITYJET is able to sweep on both right and left side simultaneously if the operator chooses to do so.
- ▶ Our Pure Vacuum sweeping system allows for sweeping heavy debris such as rocks, sand as well as leaves and light debris.
- ▶ The water system includes 502 gallons of water and a PM10 dust suppression system. Independent flow control allows for precise water/dust management.
- ▶ The large on-board water capacity allows for sweeping all day without stopping to refill.
- ▶ Vacuum system sweeping fan powered by hydraulic pump, reducing maintenance and total cost of operation.

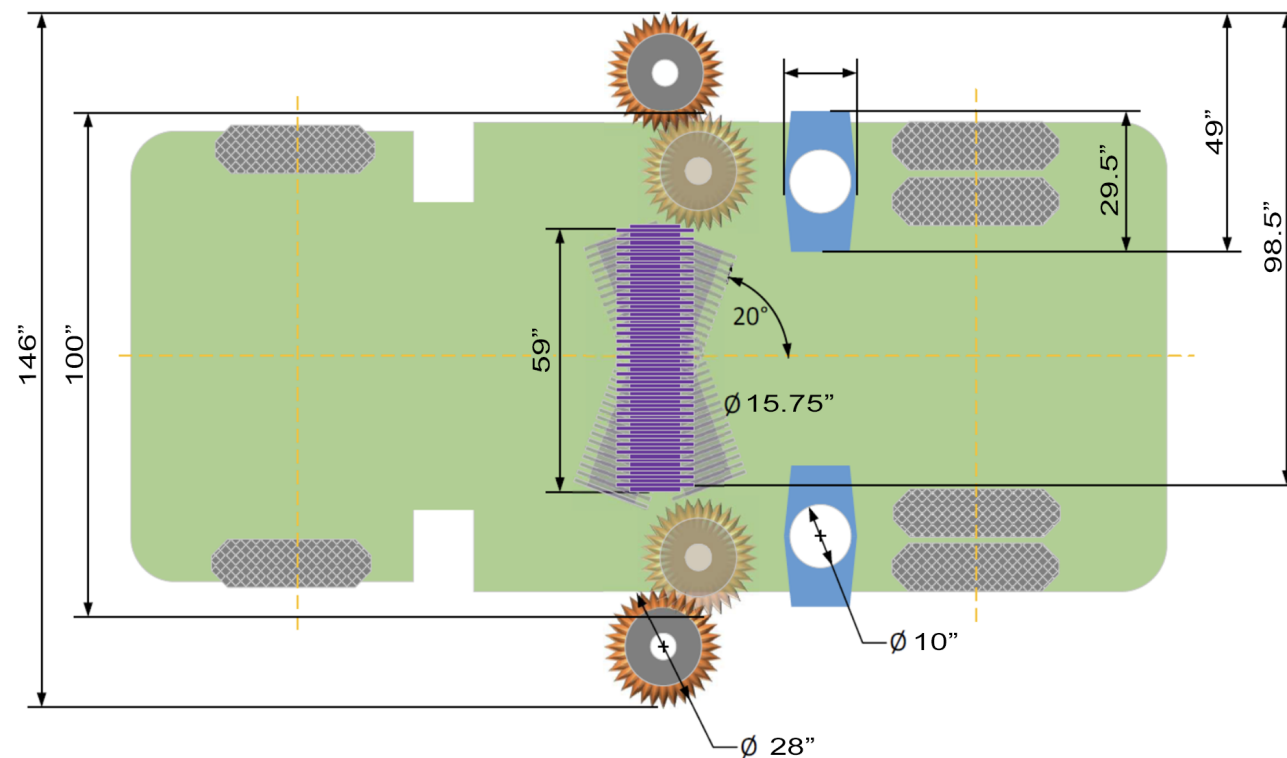

## PERFECT SOLUTION FOR MUNICIPALITIES THAT WANT IT ALL



### 1 • HIGH CAPACITY HOPPER

Features an **8.5 cu.yd. Stainless Steel Hopper** with a steep 60° dump angle for efficient material discharge with hopper wash-out system. Hopper screen pneumatic shaker and hopper full indicator all included.

### 2 • ENHANCED SAFETY

Equipped with an automatically activated safety prop to secure the hopper during maintenance.



### 3 • ADVANCED TAILGATE DESIGN

The rear tailgate opens to a wide 95° angle for easy access.

### 4 • DUAL-HAND SAFETY CONTROLS

A rear-mounted control panel requires two-handed operation to ensure maximum operator safety during tailgate closing.

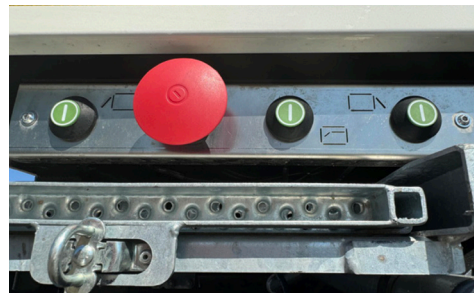

### 5 • ALL-DAY WATER SUPPLY

A heavy-duty 502-gallon polyethylene water tank provides ample capacity for full-shift operation.

### 6 • POWERFUL SUCTION SYSTEM

Includes a 29.5" suction nozzle with a replaceable liner and a heavy-duty 10" diameter suction hose.

### 7 • DUAL GUTTER BROOMS

Large 28" gutter brooms with simultaneous sweep also feature full in-cab adjustments for both speed and downward pressure.

### 8 • VERSATILE MAIN BROOM

The 59" x 15.75" main broom pivots 20° to either side, with integrated in-cab speed and pressure controls.

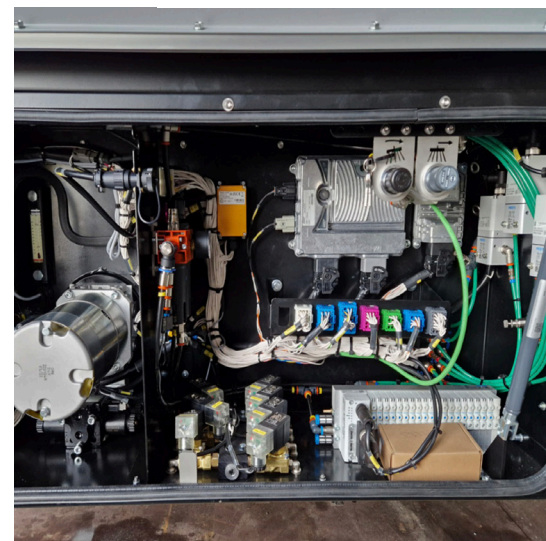

### 9 • CENTRALIZED SYSTEMS LOCKER

**Left Side:** Pneumatic and Hydraulic manifolds are all located in one enclosed locker allowing for easy diagnostics and maintenance. **Right Side:** Accessory Storage Toolbox and additional catch basin suction tube extension storage.

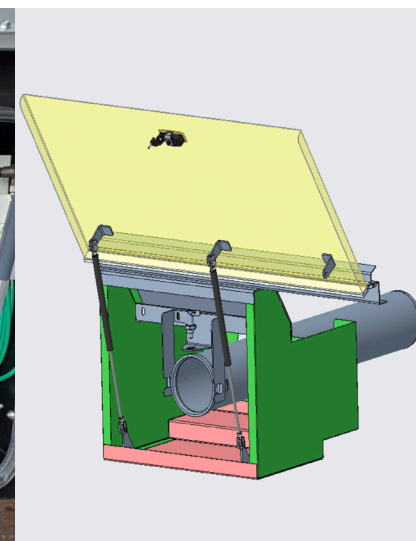

### 10 • EFFICIENT POWER PLANT

Driven by a **DEUTZ 3.6L (136 hp)** Turbo Diesel engine, featuring High-Performance Hydraulic System and High-Power Suction Fan, sweeping heavy debris is easy.

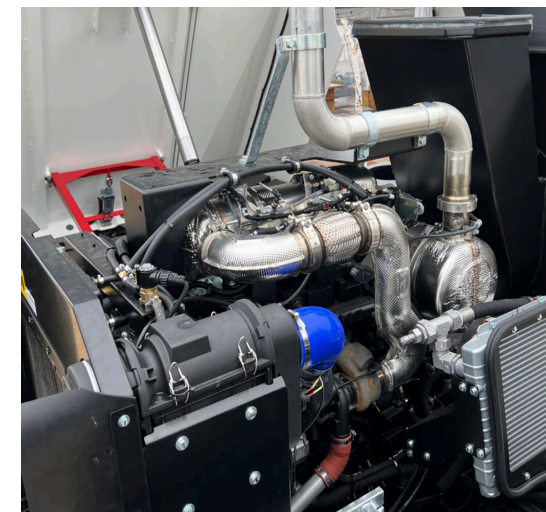

### 11 • TOP MOUNTED CATCH BASIN HOSE

Includes a 8" top-mounted hose with a 300° reach. 8" rear door mounted hose option available upon request.

### 12 • PM10 DUST SUPPRESSION

Hydraulically driven water pump delivers up to 10 GPM at 58 PSI, with independent valves that allow for precise control of water flow required for dust control.

### 13 • ERGONOMIC OPERATOR INTERFACE

All critical displays and instruments are ergonomically arranged within the in-cab control center for intuitive operation.



**Remote Control With Advanced Functions** Includes Suction Fan mode adjustments with two additional programmable functions of your choice. All critical displays and instruments are ergonomically arranged within the in-cab control center for intuitive operation.



### 14 • HIGH-PRESSURE WASH SYSTEM

Includes a high-pressure wash-down system delivering 4 GPM @ 1450 PSI. **Optional** high-pressure package includes 8-gallon 1450 PSI water pump with 50' hose reel and hand-held lance, high-pressure street washing spray bars behind each suction nozzle and center broom with independent flow control valves.

### GLOBAL CITYJET Standard Equipment

- 100% Stainless Steel Hopper Construction
- DEUTZ 3.6 Liter 136HP Turbo Diesel Engine with High-Performance Hydraulic System and High-Power Suction Fan
- Dual Gutterbroom Simultaneous Sweep
- In-Cab Gutterbroom Tilt & Down Pressure Adjustment
- In-Cab GB and Center Broom Speed Control
- Suction Fan Wash-Out w/shut-off Valve
- Hopper Wash Out System with separate High-Flow Modules
- Pneumatic Shaker System for Hopper Screen
- Hopper Full Indicator
- Dual LED Hopper Beacons
- High Pressure Washing System rated at 1450 PSI with 50' Reel and Lance
- Rear View Camera with 7" LCD Monitor
- Right-Hand & Left-Hand Steering With Gauge Console